

TECHNICAL DATA

Three Phase Electric Motors - Cast Iron Frame

PE30 160 L 6 IE3

11 kW / 15 Cv

980 RPM

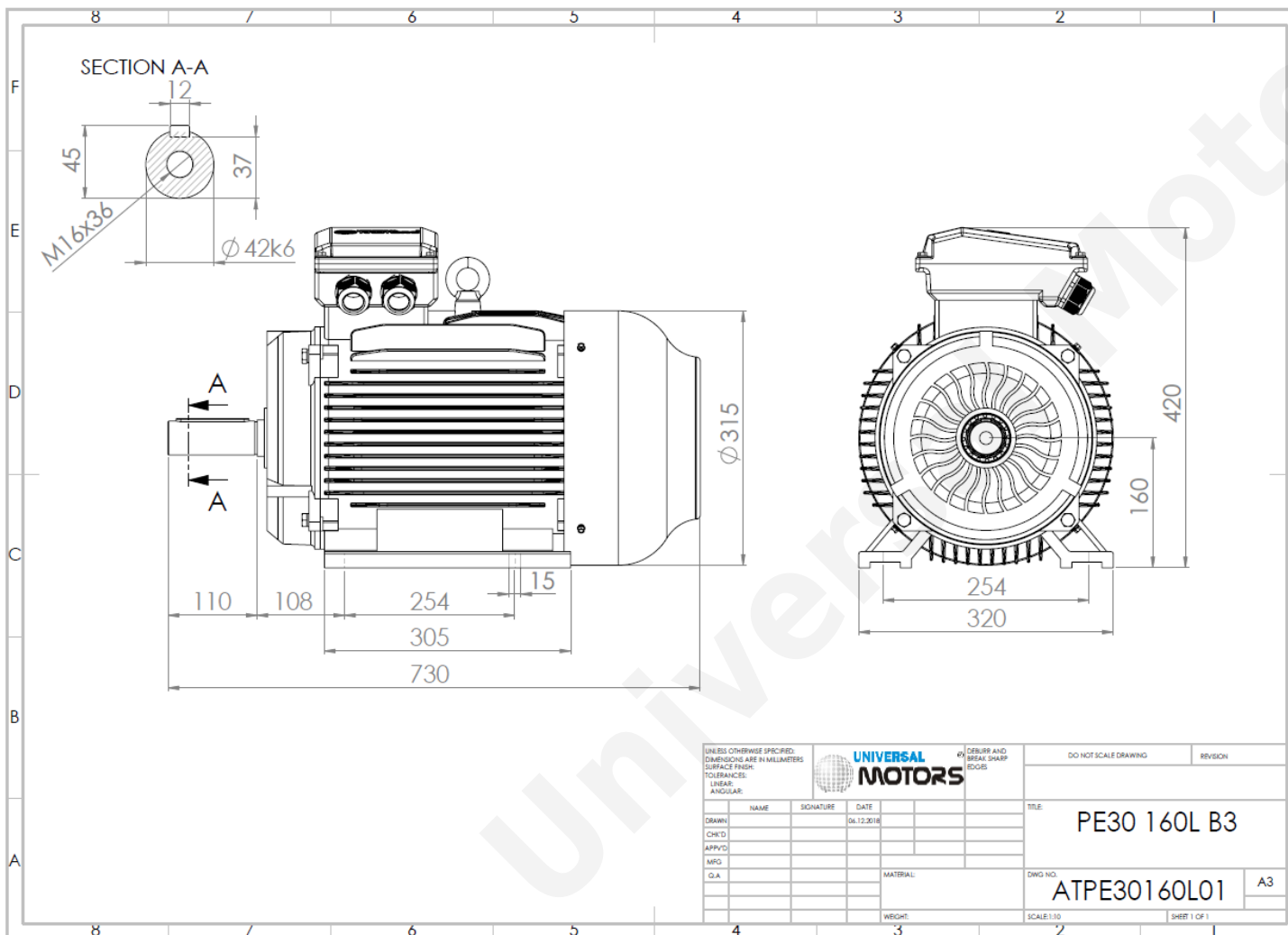

Motor type:	PE30 160 L 6 IE3
Output:	11 kW / 15 Cv
Speed (min^{-1}):	980 RPM
Frequency:	50 Hz
Voltage:	400 V
Current:	22.0 A
Power factor ($\text{Cos } \phi$):	0.80
Poles:	6
Insulation class:	F
Temperature rise Class:	B
Efficiency 50%:	89.6 %
Efficiency 75%:	90.9 %
Efficiency 100%:	90.4 %
Torque:	107 N.m
Tstarting/Tnominal:	2.0
Istarting/Inominal:	7.2
Tmaximum/Tnominal:	2.1
Noise:	62 Db(A)
Weight:	160 Kg
Bearing DE:	6309 C3
Bearing NDE:	6309 C3

Regime - S1

Altitude - 1000m

Environment Temperature - 40°C

CONTACTS:

UNIVERSAL MOTORS Tel: +351 252 299 080
 Rua de São Brás, 745 Fax: +351 252 299 089
 4480-782 VILA DO CONDE Mail: geral@universalmotors.pt

* References applied only in the UK